

# NEBRASKA OECD TRACTOR TEST 2106—SUMMARY 984

## JOHN DEERE 6215R AUTOQUAD-PLUS DIESEL

### 20 SPEED

#### POWER TAKE-OFF PERFORMANCE

Power HP (kW)	Crank shaft speed rpm	Diesel Consumption		D.E.F. Consumption		Mean Atmospheric Conditions
		Gal/hr (l/h)	lb/hp.hr (kg/kW.h)	Hp.hr/gal (kW.h/l)	Gal/hr (l/h)	
<b>MAXIMUM POWER AND FUEL CONSUMPTION</b>						
<b>Rated Engine Speed—(PTO speed—1073 rpm)</b>						
181.06 (135.02)	2102	10.48 (39.69)	0.406 (0.247)	17.27 (3.40)	0.34 (1.30)	Fuel used during active exhaust regeneration-1.30 gal (4.91 l) (see note 1, p.2)
<b>Standard Power Take-off Speed (1000 rpm)</b>						
203.63 (151.84)	1959	11.33 (42.90)	0.390 (0.237)	17.97 (3.54)	0.36 (1.37)	
<b>Maximum Power (1 hour)</b>						
205.72 (153.41)	1800	11.30 (42.77)	0.385 (0.234)	18.21 (3.59)	0.35 (1.33)	

#### VARYING POWER AND FUEL CONSUMPTION

181.06 (135.02)	2102	10.48 (39.69)	0.406 (0.247)	17.27 (3.40)	0.34 (1.30)	Air temperature
157.95 (117.79)	2161	9.58 (36.27)	0.425 (0.259)	16.49 (3.25)	0.32 (1.21)	75°F (24°C)
119.99 (89.48)	2187	7.86 (29.76)	0.459 (0.279)	15.26 (3.01)	0.29 (1.11)	Relative humidity
81.38 (60.69)	2225	6.39 (24.20)	0.551 (0.335)	12.73 (2.51)	0.24 (0.91)	51%
41.30 (30.80)	2245	4.64 (17.55)	0.786 (0.478)	8.91 (1.76)	0.23 (0.86)	Barometer
3.36 (2.50)	2250	2.96 (11.20)	6.171 (3.754)	1.14 (0.22)	0.24 (0.90)	28.89" Hg (97.84 kPa)

Maximum torque - 684 lb.-ft. (927 Nm) at 1301 rpm

Maximum torque rise - 51.2%

Torque rise at 1681 engine rpm - 42%

Power increase at 1800 engine rpm - 13.6%

#### DRAWBAR PERFORMANCE UNBALLASTED - FRONT DRIVE ENGAGED FUEL CONSUMPTION CHARACTERISTICS

Power Hp (kW)	Drawbar pull lbs (kN)	Speed mph (km/h)	Crank- shaft speed rpm	Slip %	Fuel Consumption lb/hp.hr (kg/kW.h)	D.E.F. Consumption lb/hp.hr (kg/kW.h)	Temp. °F(°C) cool- ing med	Air dry bulb	Barom. inch Hg (kPa)	
<b>Maximum Power—8th (C1) Gear</b>										
173.89 (129.67)	11466 (51.00)	5.69 (9.16)	2099	2.9	0.425 (0.258)	16.50 (3.25)	0.012 (0.008)	202 (94)	69 (21)	28.52 (96.58)
<b>75% of Pull at Maximum Power—8th (C1) Gear</b>										
136.86 (102.05)	8571 (38.13)	5.99 (9.64)	2192	2.1	0.451 (0.274)	15.55 (3.06)	0.013 (0.008)	198 (92)	75 (24)	28.49 (96.48)
<b>50% of Pull at Maximum Power—8th (C1) Gear</b>										
93.07 (69.40)	5724 (25.46)	6.10 (9.82)	2216	1.4	0.523 (0.318)	13.41 (2.64)	0.010 (0.006)	192 (89)	75 (24)	28.50 (96.51)
<b>75% of Pull at Reduced Engine Speed—11th (C3) Gear</b>										
136.49 (101.78)	8526 (37.92)	6.00 (9.66)	1524	2.1	0.406 (0.247)	17.28 (3.40)	0.010 (0.006)	200 (93)	75 (24)	28.52 (96.58)
<b>50% of Pull at Reduced Engine Speed—11th (C3) Gear</b>										
93.13 (69.45)	5672 (25.23)	6.16 (9.91)	1552	1.3	0.444 (0.270)	15.78 (3.11)	0.010 (0.006)	188 (86)	75 (24)	28.53 (96.61)

**Location of tests:** Nebraska Tractor Test Laboratory, University of Nebraska, Lincoln, Nebraska 68583-0832

**Dates of tests:** June 23 - 30, 2015

**Manufacturer:** John Deere Tractor Works, 3500 East Donald Street, P.O. Box 270, Waterloo Ia, 50704-0270

**CONSUMABLE Fluids, OIL and TIME: Fuel** No. 2 Diesel **Specific gravity converted to 60°/60°F (15°/15°C)** 0.8415 **Fuel weight** 7.007 lbs/gal (0.840 kg/l) **Diesel Exhaust Fluid (DEF)** 32% aqueous urea solution **DEF weight** 9.071 lbs/gal (1.087 kg/l) **Oil SAE 10W-30 API service classification** CJ-4 **Transmission and hydraulic lubricant** John Deere Hy-Gard fluid **Front axle lubricant** John Deere Hy-Gard fluid **Total time engine was operated:** 22.5 hours

**ENGINE: Make** John Deere **Diesel Type** six cylinder vertical with two turbochargers, air to air intercooler and D.E.F. (diesel exhaust fluid) exhaust treatment **Serial No.** \*PE6068U007111\* **Crankshaft** lengthwise **Rated engine speed** 2100 **Bore and stroke** 4.19 x 5.00" (106.5 mm x 127.0 mm) **Compression ratio** 17.0 to 1 **Displacement** 414 cu in (6788 ml) **Starting system** 12 volt **Lubrication** pressure **Air cleaner** two paper elements and aspirator **Oil filter** one full flow cartridge **Oil cooler** engine coolant heat exchanger for crankcase oil, radiator for hydraulic and transmission oil **Fuel filter** one paper element and prestrainer **Fuel cooler** radiator for pump return fuel **Exhaust** DOC (diesel oxidation catalyst), SCR (selective catalyst reduction) and regenerative DPF (diesel particulate filter) integrated within a vertical muffler **Cooling medium temperature control** 2 thermostats and 2 variable speed fans

**ENGINE OPERATING PARAMETERS: Fuel rate:** 70.3 - 74.5 lb/h (31.9 - 33.8 kg/h) **High idle:** 2225 - 2275 rpm **Turbo boost:** nominal 18.1 - 21.0 psi (125 - 145 kPa) as measured 19.4 psi (134 kPa)

**CHASSIS: Type** front wheel assist with duals **Serial No.** \*1RW6215RTFA020286\* **Tread width** rear 60.0" (1524 mm) to 124.6" (3164 mm) front 58.8" (1494 mm) to 86.9" (2206 mm) **Wheelbase** 110.2" (2800 mm) **Hydraulic control system** direct engine drive **Transmission** selective gear fixed ratio with partial (4) range operator controlled power shift **Nominal travel speeds mph (km/h)** first 1.74 (2.80) second 2.09 (3.37) third 2.50 (4.03) fourth 3.07 (4.94) fifth 3.68 (5.93) sixth 4.44 (7.14) seventh 5.31 (8.55) eighth 5.86 (9.43) ninth 6.51 (10.47) tenth 7.06 (11.36) eleventh 8.45 (13.60) twelfth 10.35 (16.66) thirteenth 10.85 (17.46) fourteenth 13.07 (21.03) fifteenth 15.65 (25.18) sixteenth 19.17 (30.85) seventeenth 19.80 (31.86) eighteenth 23.84 (38.37) nineteenth 26.10 (42.00) twentieth 26.10 (42.00) electronically limited

## DRAWBAR PERFORMANCE

### UNBALLASTED - FRONT DRIVE ENGAGED - 2100 RPM MAXIMUM POWER IN SELECTED GEARS

Power Hp (kW)	Drawbar pull lbs (kN)	Speed mph (km/h)	Crank- shaft speed rpm	Slip %	Fuel Consumption lb/hp.hr (kg/kW.h)	D.E.F. Consumption Hp.hr/gal (kg/kW.h)	Temp. °F(°C) cool- ing dry bulb	Barom. inch Hg (kPa)	
4th(A4) Gear									
142.64 (106.36)	19897 (88.50)	2.69 (4.33)	2138	14.5	0.496 (0.302)	14.12 (2.78)	0.014 (0.009)	198 70 (92) (21)	28.71 (97.22)
5th(B1) Gear									
167.14 (124.64)	18278 (81.30)	3.43 (5.52)	2100	6.9	0.442 (0.269)	15.86 (3.12)	0.013 (0.008)	204 69 (96) (21)	28.72 (97.26)
6th(B2) Gear									
170.02 (126.78)	15027 (66.84)	4.24 (6.82)	2100	4.3	0.434 (0.264)	16.14 (3.18)	0.013 (0.008)	197 68 (91) (20)	28.51 (96.55)
7th(B3) Gear									
171.77 (128.09)	12536 (55.76)	5.14 (8.27)	2100	3.2	0.428 (0.260)	16.37 (3.23)	0.013 (0.008)	198 67 (92) (19)	28.51 (96.55)
8th(C1) Gear									
173.89 (129.67)	11466 (51.00)	5.69 (9.16)	2099	2.9	0.425 (0.258)	16.50 (3.25)	0.012 (0.008)	202 69 (94) (21)	28.52 (96.58)
9th(B4) Gear									
173.31 (129.24)	10254 (45.61)	6.34 (10.20)	2100	2.6	0.426 (0.259)	16.45 (3.24)	0.013 (0.008)	201 71 (94) (22)	28.51 (96.55)
10th(C2) Gear									
173.37 (129.28)	9440 (41.99)	6.89 (11.09)	2099	2.3	0.425 (0.259)	16.48 (3.25)	0.013 (0.008)	200 70 (93) (21)	28.52 (96.58)
11th(C3) Gear									
173.50 (129.38)	7853 (34.93)	8.29 (13.33)	2099	1.9	0.423 (0.257)	16.57 (3.26)	0.013 (0.008)	202 71 (94) (22)	28.51 (96.55)

reverse 1.81 (2.92), 2.18 (3.51), 2.61 (4.21), 3.20 (5.15), 3.84 (6.18), 4.63 (7.45), 5.54 (8.91), 6.11 (9.84), 6.79 (10.93), 7.36 (11.85), 8.82 (14.19), 10.81 (17.39), 11.32 (18.22), 13.63 (21.94), 17.57 (26.28), 20.00 (32.19), 20.66 (33.25), 24.87 (40.03), 26.10 (42.00), 26.10 (42.00) electronically limited **Clutch** wet multiple disc hydraulically actuated by foot pedal **Brakes** wet multiple disc hydraulically operated by two foot pedals that can be locked together **Steering** hydrostatic **Power take-off** 540 rpm at 1960 engine rpm or 1000 rpm at 1960 engine rpm **Unladen tractor mass** 18725 lb (8494 kg)

**NOTE 1:** The manufacturer declares that the average time between active regenerations is 50 hours, while operated in Auto Filter Cleaning Mode, at rated speed, full load, under steady state conditions.

**REPAIRS AND ADJUSTMENTS:** No repairs or adjustments.

**REMARKS:** All test results were determined from observed data obtained in accordance with official OECD, SAE and Nebraska test procedures. The performance figures on this summary were taken from a test conducted under the OECD Code 2 test code procedure.

We, the undersigned, certify that this is a true and correct report of official Tractor Test No. **2106**, Nebraska Summary 984, July 19, 2015.

Roger M. Hoy  
Director

M.F. Kocher  
P.J. Jasa  
S. K. Pitla  
Board of Tractor Test Engineers

### TRACTOR SOUND LEVEL WITH CAB

	Front Wheel Drive Engaged dB(A)	Disengaged dB(A)
At no load in 6th (B2) gear	69.8	69.9
Transport speed - no load - 18th (F2) gear		72.6
Bystander in 18th (E2) gear		82.3

### TIRES, BALLAST AND WEIGHT

	With Ballast	Without Ballast
<b>Rear Tires</b> - No., size, ply & psi(kPa)	Four 480/80R46;***;12(85)	Four 480/80R46;***;12(85)
<b>Ballast</b> - Liquid (total)	None	None
- Cast Iron (total)	3045 lb (1381 kg)	None
<b>Front Tires</b> - No., size, ply & psi(kPa)	Two 420/90R30;***;17(115)	Two 420/90R30;***;12(85)
<b>Ballast</b> - Liquid (total)	None	None
- Cast Iron (total)	2030 lb (921 kg)	None
<b>Height of Drawbar</b>	21.0 in (510 mm)	21.0 in (535 mm)
<b>Static Weight with operator</b> - Rear	15125 lb (6861 kg)	12660 lb (5743 kg)
- Front	8850 lb (4014 kg)	6240 lb (2830 kg)
- Total	23975 lb (10875 kg)	18900 lb (8573 kg)

**DRAWBAR PERFORMANCE**  
**UNBALLASTED - FRONT DRIVE ENGAGED - 1800 RPM**  
**MAXIMUM POWER IN SELECTED GEARS**

Power Hp (kW)	Drawbar pull lbs (kN)	Speed mph (km/h)	Crank- shaft speed rpm	Slip %	Fuel Consumption lb/hp.hr (kg/kW.h)	Hp.hr/gal (kW.h/l)	D.E.F. Consumption lb/hp.hr (kg/kW.h)	Temp. °F(°C) cool- ing med	Air dry bulb	Barom. inch Hg (kPa)
4th(A4) Gear										
143.03 (106.66)	19893 (88.49)	2.70 (4.35)	2137	14.2	0.496 (0.302)	14.13 (2.78)	0.014 (0.008)	198 (92)	70 (21)	28.72 (97.26)
5th(B1) Gear										
167.61 (124.99)	18367 (81.70)	3.42 (5.50)	2100	7.1	0.441 (0.268)	15.89 (3.13)	0.013 (0.008)	205 (96)	69 (21)	28.72 (97.26)
6th(B2) Gear										
184.78 (137.79)	17573 (78.17)	3.95 (6.35)	1989	6.1	0.426 (0.259)	16.46 (3.24)	0.013 (0.008)	204 (96)	69 (21)	28.73 (97.29)
7th(B3) Gear										
192.30 (143.40)	16784 (74.66)	4.30 (6.92)	1800	5.6	0.411 (0.250)	17.06 (3.36)	0.013 (0.008)	205 (96)	69 (21)	28.52 (96.58)
8th(C1) Gear										
193.76 (144.48)	15114 (67.23)	4.81 (7.74)	1800	4.2	0.408 (0.248)	17.18 (3.38)	0.013 (0.008)	205 (96)	70 (21)	28.52 (96.58)
9th(B4) Gear										
195.22 (145.58)	13633 (60.64)	5.37 (8.64)	1800	3.8	0.405 (0.246)	17.32 (3.41)	0.013 (0.008)	205 (96)	71 (22)	28.51 (96.55)
10th(C2) Gear										
195.94 (146.11)	12559 (55.86)	5.85 (9.41)	1800	3.2	0.404 (0.246)	17.33 (3.41)	0.013 (0.008)	207 (97)	70 (21)	28.52 (96.58)
11th(C3) Gear										
196.86 (146.79)	10470 (46.57)	7.05 (11.35)	1800	2.6	0.401 (0.244)	17.48 (3.44)	0.013 (0.008)	208 (98)	71 (22)	28.51 (96.55)
12th(C4) Gear										
195.49 (145.77)	8438 (37.53)	8.69 (13.99)	1800	2.0	0.403 (0.245)	17.37 (3.42)	0.013 (0.008)	209 (98)	72 (22)	28.51 (96.55)

**DRAWBAR PERFORMANCE**  
**BALLASTED - FRONT DRIVE ENGAGED - 1800 RPM**  
**MAXIMUM POWER IN SELECTED GEARS**

Power Hp (kW)	Drawbar pull lbs (kN)	Speed mph (km/h)	Crank- shaft speed rpm	Slip %	Fuel Consumption lb/hp.hr (kg/kW.h)	Hp.hr/gal (kW.h/l)	D.E.F. Consumption lb/hp.hr (kg/kW.h)	Temp. °F(°C) cool- ing med	Air dry bulb	Barom. inch Hg (kPa)
3rd (A3) Gear										
147.16 (109.74)	24930 (110.89)	2.22 (3.56)	2129	12.6	0.484 (0.295)	14.47 (2.85)	0.013 (0.008)	202 (94)	70 (21)	28.77 (97.43)
4th (A4) Gear										
170.48 (127.12)	23528 (104.66)	2.72 (4.38)	2029	8.4	0.451 (0.274)	15.53 (3.06)	0.013 (0.008)	201 (94)	70 (21)	28.77 (97.43)
5th (B1) Gear										
187.64 (139.92)	22041 (98.04)	3.20 (5.14)	1947	6.2	0.425 (0.258)	16.50 (3.25)	0.013 (0.008)	205 (96)	71 (22)	28.77 (97.43)
6th(B2) Gear										
190.60 (142.13)	19839 (88.25)	3.60 (5.79)	1800	4.8	0.415 (0.253)	16.88 (3.33)	0.014 (0.009)	207 (97)	72 (22)	28.77 (97.43)
7th(B3) Gear										
194.68 (145.17)	16713 (74.34)	4.37 (7.03)	1800	3.6	0.406 (0.247)	17.24 (3.40)	0.014 (0.008)	207 (97)	72 (22)	28.78 (97.46)
8th(C1) Gear										
195.59 (145.85)	15146 (67.37)	4.84 (7.79)	1800	3.1	0.405 (0.246)	17.30 (3.41)	0.013 (0.008)	207 (97)	72 (22)	28.78 (97.46)
9th(B4) Gear										
195.37 (145.58)	13576 (60.39)	5.40 (8.69)	1800	2.7	0.405 (0.246)	17.30 (3.41)	0.013 (0.008)	208 (98)	73 (23)	28.78 (97.46)
10th(C2) Gear										
195.21 (145.56)	12472 (55.48)	5.87 (9.45)	1800	2.5	0.406 (0.247)	17.28 (3.40)	0.013 (0.008)	206 (96)	73 (23)	28.78 (97.46)
11th(C3) Gear										
195.14 (145.51)	10361 (46.09)	7.06 (11.36)	1800	2.0	0.406 (0.247)	17.27 (3.40)	0.013 (0.008)	204 (96)	74 (24)	28.77 (97.43)
12th(C4) Gear										
193.05 (143.96)	8330 (37.05)	8.70 (13.99)	1800	1.6	0.408 (0.248)	17.17 (3.38)	0.014 (0.008)	204 (96)	76 (24)	28.77 (97.43)

## HYDRAULIC PERFORMANCE

CATEGORY: III

Quick Attach: No

Lift cylinders:

2 x 90 mm

Maximum force exerted through whole range: 12660 lbs (56.3 kN)

i) Sustained pressure at compensator cutoff: 2839 psi (196 bar)

**three outlet sets combined**

ii) Pump delivery rate at minimum pressure and rated engine speed: 41.1 GPM (155.4 l/min)

iii) Pump delivery rate at maximum hydraulic power: 39.4 GPM (149.3 l/min)

Delivery pressure: 2498 psi (172 bar)

Power: 57.5 HP (42.9 kW)

**single outlet set**

ii) Pump delivery rate at minimum pressure and rated engine speed: 32.4 GPM (122.7 l/min)

iii) Pump delivery rate at maximum hydraulic power: 30.3 GPM (114.7 l/min)

Delivery pressure: 2196 psi (151 bar)

Power: 38.8 HP (28.9 kW)

## HITCH DIMENSIONS AS TESTED—NO LOAD

	inch	mm
A	29.3	745
B	16.1	410
C	24.6	624
D	23.8	605
E	7.5	190
F	10.8	275
G	38.4	975
H	4.1	105
I	21.8	554
J	27.6	700
K	26.2	666
L	51.3	1303
M	26.9	683
N	43.6	1108
O	9.0	230
P	54.5	1385
Q	40.1	1018
R	43.9	1115

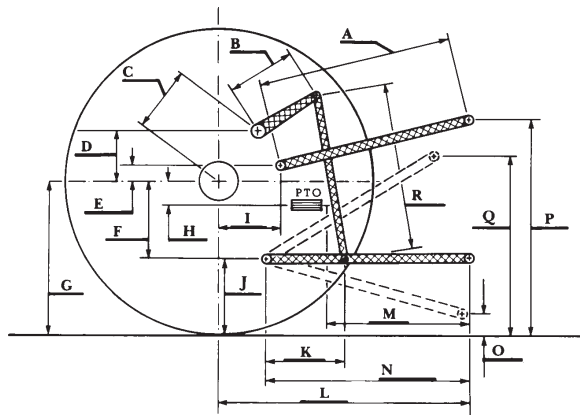

**JOHN DEERE 6215R DIESEL**