

# LF 180

## FA 4x2 rigid, 16t



### Engines

LF 180 PX-5 (135 kW / 184 hp)  
 LF 210 PX-5 (157 kW / 213 hp)  
 LF 220 PX-7 (164 kW / 223 hp)  
 LF 250 PX-7 (186 kW / 253 hp)  
 LF 280 PX-7 (208 kW / 283 hp)

### GVM

16000 kg  
 Max. front<sup>1)</sup>: 6000 kg  
 Max. rear: 10500 kg

### GCM

16000 kg

Wheelbase - AE	Unladen weight <sup>2)</sup>			Gross Carrying Capacity			Variable dimensions														
	WB	AE <sup>3)</sup>		Front	Rear	Total	Front	Rear	Total	AC	CB <sup>4)</sup>	CH <sup>5)</sup>	BL <sup>6)</sup>	BL <sup>6)</sup>	TL	HA <sup>7)</sup>	HA <sup>9)</sup>	TK <sup>9)</sup>	TW <sup>10)</sup>		
14-16t	Day Cab																				
	3.25	1.70		2751	1353	4104	3249	9147	11896	0.28	0.12	1.88	3.90	4.30	6.28	1.05	0.90	11.11	12.53		
	3.50	1.85		2727	1412	4139	3273	9088	11861	0.28	0.12	1.88	4.20	4.60	6.68	1.05	0.90	11.73	13.16		
	3.80	2.03		2727	1432	4159	3273	9068	11841	0.28	0.12	1.88	4.70	5.10	7.16	1.05	0.90	12.47	13.91		
	4.20	2.27		2728	1456	4184	3272	9044	11816	0.28	0.12	1.88	5.20	5.70	7.80	1.05	0.90	13.46	14.92		
	4.50	2.45		2738	1486	4224	3262	9014	11776	0.28	0.12	1.88	5.70	6.20	8.28	1.05	0.90	14.21	15.68		
	4.80	2.63		2739	1500	4239	3261	9000	11761	0.28	0.12	1.88	6.10	6.60	8.76	1.05	0.90	14.95	16.44		
	5.35	2.96		2754	1545	4299	3246	8955	11701	0.28	0.12	1.88	6.90	7.50	9.64	1.05	0.90	16.33	17.83		
	5.90	3.29		2765	1584	4349	3235	8916	11651	0.28	0.12	1.88	7.70	8.30	10.52	1.05	0.90	17.70	19.22		
	6.30	3.53		2770	1609	4379	3230	8891	11621	0.28	0.12	1.88	8.30	8.90	11.16	1.05	0.90	18.71	20.23		
	Sleeper Cab																				
	3.25	1.70		2861	1373	4234	3139	9127	11766	0.68	0.07	1.88	3.20	3.60	6.28	1.05	0.90	11.11	12.53		
	3.50	1.85		2842	1432	4274	3158	9068	11726	0.68	0.07	1.88	3.60	4.00	6.68	1.05	0.90	11.73	13.16		
	3.80	2.03		2842	1452	4294	3158	9048	11706	0.68	0.07	1.88	4.00	4.50	7.16	1.05	0.90	12.47	13.91		
4.20	2.27		2848	1471	4319	3152	9029	11681	0.68	0.07	1.88	4.60	5.10	7.80	1.05	0.90	13.46	14.92			
4.50	2.45		2853	1501	4354	3147	8999	11646	0.68	0.07	1.88	5.10	5.50	8.28	1.05	0.90	14.21	15.68			
4.80	2.63		2859	1515	4374	3141	8985	11626	0.68	0.07	1.88	5.50	6.00	8.76	1.05	0.90	14.95	16.44			
5.35	2.96		2874	1555	4429	3126	8945	11571	0.68	0.07	1.88	6.30	6.90	9.64	1.05	0.90	16.33	17.83			
5.90	3.29		2885	1599	4484	3115	8901	11516	0.68	0.07	1.88	7.10	7.70	10.52	1.05	0.90	17.70	19.22			
6.30	3.53		2885	1624	4509	3115	8876	11491	0.68	0.07	1.88	7.70	8.30	11.16	1.05	0.90	18.71	20.23			

Other dimensions VA: 1.33 HV<sup>11)</sup>: 0.94 HV<sup>12)</sup>: 0.82 RB: 0.79 SB: 1.75 TB: 2.35

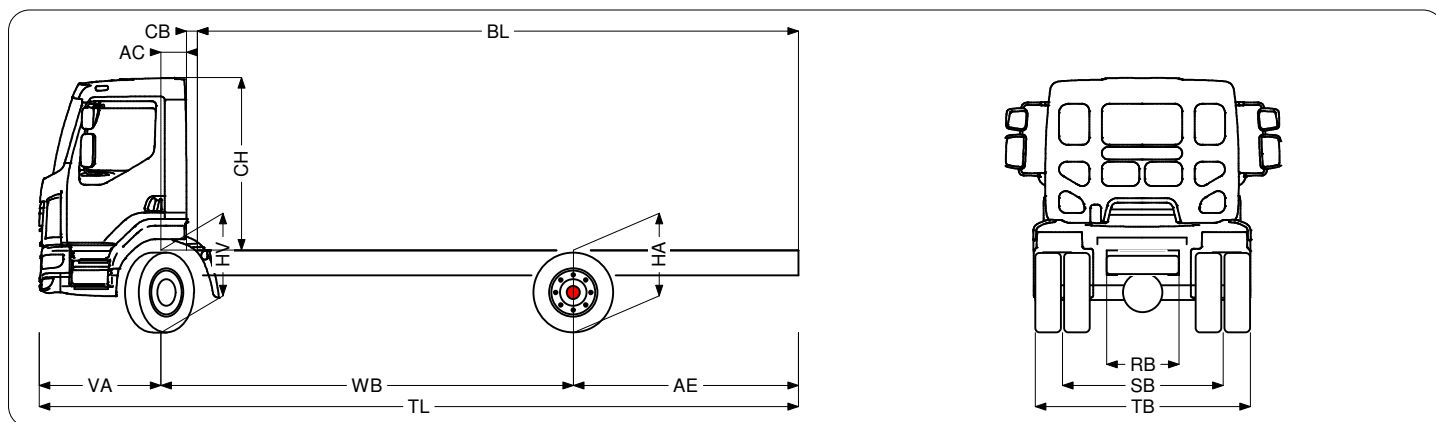

1) Axle load with standard tyre size.  
 2) Chassis and Cab Weight calculated with: Standard specification items only with 17 litres of fuel, 15 litres of AdBlue and driver of 0 kg, tolerance ± 3%. Changing of the specification can have major impact on vehicle weight.  
 3) Other AE dimensions may be available for shown WB. Modify rear overhang to the calculated body length.  
 4) CB is based on standard air intake and/or exhaust.  
 5) Cab height is measured from frame member to closed cabin roof hatch.  
 6) Calculate customer specific body length with TOPEC. Body lengths shown based on evenly distributed load at max axle load.  
 7) Unladen height at centre of driven axle(s).  
 8) Laden height at centre of driven axle(s).  
 9) TK = turning circle between kerbs.  
 10) TW = turning circle between walls.  
 11) Unladen height at centre of front axle(s).  
 12) Laden height at centre of front axle(s).

# LF 180

## FA 4x2 rigid, 16t

### Cab exterior

Day Cab with steel bumper, tinted glass and electric window openers. Main mirrors and wide angle mirrors electrically heated. Cab width 2130 mm; Front view mirror; Electrically adjustable mirrors.

Optional:

- Extended Day Cab
- Sleeper Cab
- Cab suspension mechanical reinforced
- Cab suspension rubber and mechanical
- Fog lights
- Fog lights and cornering lights

### Aerodynamics

Optional:

- Side collars
- Side collars prepared
- Various types of roofspoilers and settings

### Colours

Cab colour H3279 Brilliant White; Head lamp panel and bumper: Stone Grey; Chassis colour grey.

Optional:

- Head lamp panel and bumper: cab colour
- Various cab and chassis colours see colour guide

### Cab interior

Driver seat: air suspended; Co-driver seat: fixed velour; Storage box on engine tunnel.

Optional:

- Air bag (driver) and 2 seat belt tensioners
- Steering wheel, black leather
- Roof hatch, manual control
- Roof hatch, electric control
- Lower bunk, normal level
- Auxiliary cab heater Air Top 2000
- Air conditioning
- Various types of drivers and co-drivers seats

### Communication and driving management

FMS connector prepared; Tachograph digital, Stoneridge.

Optional:

- Various makes and types of audio equipment
- TruckPhone

### Safety and security

Vehicle Stability Control (VSC); Basic engine immobiliser system.

Optional:

- Reverse warning
- Various packages of EC-ADR safety regulations

### Suspension and axles

Front axle type F60. Parabolic leaf suspension with shock absorbers and stabiliser. Max. load 6.0 tonnes; Single reduction driven rear axle type SR10.22 with parabolic leaf suspension, including shock absorbers and stabiliser. Max. load 10.5 tonnes.

Optional:

- Rear axle SR10.26
- Rear springs air

### Wheels and tyres

Front axle 1: 285/70R19.5; Rear axle 1: 285/70R19.5; Wheel protection rings silvergrey.

Optional:

- Various tyre makes and types

### Driveline

Engine PX-5, 4 cylinder diesel engine, 4.5 litres. Output 135 kW (184 hp) at 1800-2300 rpm. Max. torque 700 Nm at 1200-1800 rpm; Exhaust emission Euro 6; Manual gearbox, 6 speeds; Gearbox ratio 6.58-0.78; Rear axle ratio 4.56.

Optional:

- AS Tronic gearbox, 6 speeds
- Automatic gearbox, 5 speeds
- Manual gearbox, 9 speeds
- Gearbox direct drive

### Brake system

Exhaust brake; DAF brake system.

### Chassis

Wheelbase 4.50 m / rear overhang 2.45 m; Side member height 270 mm; DPF/SCR unit right, discharge right; Plastic fuel tank 170 l; Spray suppression; Front underrun protection (FUP); AdBlue tank 25 litres, right side chassis.

Optional:

- Spare wheel carrier right-hand side
- Rear light with LEDs

### Drawbar and trailer equipment

Closing member.

Optional:

- D-value cross member D= 7.5

### Bodies and preparations for bodying

Application connector on the cab front.

Optional:

- Application connector for hydraulic platform
- Application connector for refuse collector
- Application connector for tail lift control
- Application connector on the chassis
- Body attachment BAM 1, consoles type B

### Power take-off (PTO)

Optional:

- Front engine PTO with generator preparation 17 kW
- Indirect front engine PTO
- Various types of PTO's / position combinations

### Electrical power supply

Alternator 80 A, batteries 2x 125 Ah.

Optional:

- Alternator 100 A
- Batteries 2x175Ah

### GVM and GCM

Technical GVM max 16000 kg; Technical GCM equal to GVM.

Optional:

- Technical GCM equal to GVM+3500 kg
- Technical GCM max 24000 kg
- Technical GCM max 26000 kg
- Technical GCM max 28000 kg

### Application conditions

Moisture separator, unheated; Air intake low.

Optional:

- Cold climate
- Air intake on the cab roof

### Service and maintenance

Standard Warranty takes care of 1 year complete vehicle, 2nd year driveline and 1 year breakdown; ITS service.

### Vehicle delivery

Standard toolkit.

Depending on the vehicle configuration a specific option may not be possible. The availability and specification of this vehicle may differ per country. For further information please contact the DAF organisation. Subject to modification without prior notice.