

LF 180

FA 4x2 rigid, 10t



Engines

LF 180 PX-5 (135 kW / 184 hp)
 LF 210 PX-5 (157 kW / 213 hp)
 LF 220 PX-7 (164 kW / 223 hp)
 LF 250 PX-7 (186 kW / 253 hp)

GVM

10000 kg
 Max. front¹⁾: 4000 kg
 Max. rear: 7200 kg

GCM

13500 kg

Wheelbase - AE		Unladen weight ²⁾			Gross Carrying Capacity			Variable dimensions										
WB	AE ³⁾	Front	Rear	Total	Front	Rear	Total	AC	CB ⁴⁾	CH ⁵⁾	BL ⁶⁾	BL ⁶⁾	TL	HA ⁷⁾	HA ⁸⁾	TK ⁹⁾	TW ¹⁰⁾	
Day Cab																		
3.05	1.80	2374	1015	3389	1626	6185	6611	0.33	0.12	1.87	3.70	4.40	6.13	0.86	0.84	10.28	11.76	
3.15	1.62	2384	1000	3384	1616	6200	6616	0.33	0.12	1.87	3.80	4.50	6.05	0.86	0.84	10.52	12.01	
3.55	1.87	2395	1034	3429	1605	6166	6571	0.33	0.12	1.87	4.40	5.20	6.70	0.86	0.84	11.49	13.00	
3.90	2.12	2395	1054	3449	1605	6146	6551	0.33	0.12	1.87	4.90	5.70	7.30	0.86	0.84	12.34	13.87	
4.30	2.32	2401	1068	3469	1599	6132	6531	0.33	0.12	1.87	5.50	6.40	7.90	0.86	0.84	13.32	14.87	
4.65	2.65	2406	1098	3504	1594	6102	6496	0.33	0.12	1.87	6.10	6.90	8.57	0.86	0.84	14.18	15.74	
5.00	2.36	2446	1123	3569	1554	6077	6431	0.33	0.12	1.87	6.60	7.50	8.64	0.86	0.84	15.04	16.61	
5.40	2.32	2451	1103	3554	1549	6097	6446	0.33	0.12	1.87	7.20	8.10	8.99	0.86	0.84	16.03	17.61	
Sleeper Cab																		
3.55	1.87	2510	1054	3564	1490	6146	6436	0.73	0.07	1.87	3.80	4.80	6.70	0.86	0.84	11.49	13.00	
3.90	2.12	2515	1069	3584	1485	6131	6416	0.73	0.07	1.87	4.30	5.40	7.30	0.86	0.84	12.34	13.87	
4.30	2.32	2521	1083	3604	1479	6117	6396	0.73	0.07	1.87	5.00	6.00	7.90	0.86	0.84	13.32	14.87	
4.65	2.65	2526	1113	3639	1474	6087	6361	0.73	0.07	1.87	5.50	6.60	8.57	0.86	0.84	14.18	15.74	
5.00	2.36	2566	1138	3704	1434	6062	6296	0.73	0.07	1.87	6.00	7.20	8.64	0.86	0.84	15.04	16.61	
5.40	2.32	2571	1118	3689	1429	6082	6311	0.73	0.07	1.87	6.70	7.80	8.99	0.86	0.84	16.03	17.61	

Other dimensions VA: 1.27 HV¹¹⁾: 0.83 HV¹²⁾: 0.75 RB: 0.86 SB: 1.74 TB: 2.25

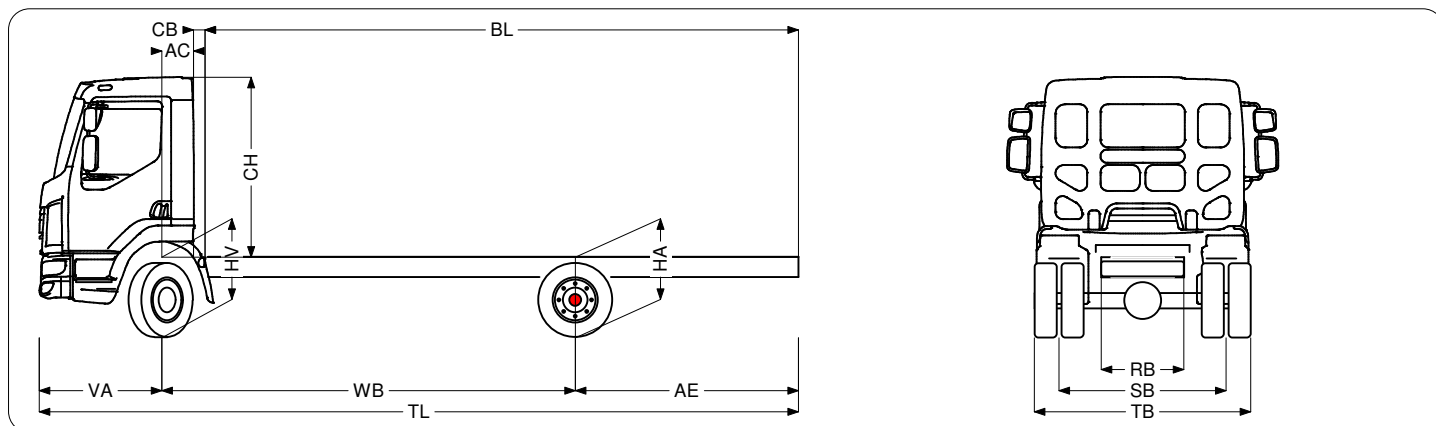

1) Axle load with standard tyre size.
 2) Chassis and Cab Weight calculated with: Standard specification items only with 11 litres of fuel, 15 litres of AdBlue and driver of 0 kg, tolerance ± 3%. Changing of the specification can have major impact on vehicle weight.
 3) Other AE dimensions may be available for shown WB. Modify rear overhang to the calculated body length.
 4) CB is based on standard air intake and/or exhaust.
 5) Cab height is measured from frame member to closed cabin roof hatch.
 6) Calculate customer specific body length with TOPEC. Body lengths shown based on evenly distributed load at max axle load.
 7) Unladen height at centre of driven axle(s).
 8) Laden height at centre of driven axle(s).
 9) TK = turning circle between kerbs.
 10) TW = turning circle between walls.
 11) Unladen height at centre of front axle(s).
 12) Laden height at centre of front axle(s).
 TOPEC III V6.8 201513a (10000)

LF 180

FA 4x2 rigid, 10t

Cab exterior

Day Cab with steel bumper, tinted glass and electric window openers. Main mirrors and wide angle mirrors electrically heated. Cab width 2130 mm; Front view mirror; Electrically adjustable mirrors.

Optional:

- Extended Day Cab
- Sleeper Cab
- Cab suspension mechanical
- Cab suspension mechanical reinforced
- Fog lights
- Fog lights and cornering lights

Aerodynamics

Optional:

- Side collars
- Side collars prepared
- Various types of roofspoilers and settings

Colours

Cab colour H3279 Brilliant White; Head lamp panel and bumper: Stone Grey; Chassis colour grey.

Optional:

- Head lamp panel and bumper: cab colour
- Various cab and chassis colours see colour guide

Cab interior

Driver seat: air suspended; Co-driver seat: fixed velour; Storage box on engine tunnel.

Optional:

- Air bag (driver) and 2 seat belt tensioners
- Steering wheel, black leather
- Roof hatch, manual control
- Roof hatch, electric control
- Lower bunk, normal level
- Auxiliary cab heater Air Top 2000
- Air conditioning
- Various types of drivers and co-drivers seats

Communication and driving management

FMS connector prepared; Tachograph digital, Stoneridge.

Optional:

- Various makes and types of audio equipment
- TruckPhone

Safety and security

Vehicle Stability Control (VSC); Basic engine immobiliser system.

Optional:

- Reverse warning
- Various packages of EC-ADR safety regulations

Suspension and axles

Front: 4.00 t, parabolic, F48; Rear: 7.20 t, parabolic, SR8.22.

Optional:

- Rear springs air
- Rear springs parabolic, asymmetric

Wheels and tyres

Front axle 1: 235/75R17.5; Rear axle 1: 235/75R17.5; Wheel protection rings silvergrey.

Optional:

- Various tyre makes and types

Driveline

Engine PX-5, 4 cylinder diesel engine, 4.5 litres. Output 135 kW (184 hp) at 1800-2300 rpm. Max. torque 700 Nm at 1200-1800 rpm; Exhaust emission Euro 6; Manual gearbox, 6 speeds; Gearbox ratio 6.02-0.79; Rear axle ratio 3.73.

Optional:

- AS Tronic gearbox, 6 speeds

Brake system

Exhaust brake; DAF brake system.

Chassis

Wheelbase 4.30 m / rear overhang 2.32 m; Side member height 210 mm; DPF/SCR unit right, discharge right; Plastic fuel tank 110 l; Spray suppression; AdBlue tank 25 litres, right side chassis.

Optional:

- Spare wheel carrier in rear overhang
- Spare wheel carrier right-hand side
- Rear light with LEDs

Drawbar and trailer equipment

Closing member.

Optional:

- D-value cross member D=7

Bodies and preparations for bodying

Application connector on the cab front.

Optional:

- Application connector for hydraulic platform
- Application connector for refuse collector
- Application connector for tail lift control
- Application connector on the chassis
- Body attachment BAM 1, consoles type B

Power take-off (PTO)

Optional:

- Indirect front engine PTO
- Various types of PTO's / position combinations

Electrical power supply

Alternator 80 A, batteries 2x 125 Ah.

Optional:

- Alternator 100 A
- Batteries 2x175Ah

GVM and GCM

Technical GVM max 10000 kg; Technical GCM equal to GVM+3500 kg.

Optional:

- Technical GCM equal to GVM
- Technical GCM max 20000 kg

Application conditions

Moisture separator, unheated; Air intake low.

Optional:

- Cold climate
- Air intake on the cab roof

Service and maintenance

Standard Warranty takes care of 1 year complete vehicle, 2nd year driveline and 1 year breakdown; ITS service.

Vehicle delivery

Standard toolkit.

Depending on the vehicle configuration a specific option may not be possible. The availability and specification of this vehicle may differ per country. For further information please contact the DAF organisation. Subject to modification without prior notice.